

640 Power Drive



Wheeler Mfg. Div Rex Intl USA Inc.
3744 Jefferson Road
Ashtabula, OH 44004
800-321-7950 • 440-992-2925
Fax: 440-992-2925

wheeler@wheelerrex.com • www.wheelerrex.com

- Be sure to observe the Safety Precautions described below to prevent accidents such as fire, electric shock and injury.
- Read these Safety Precautions carefully before using the machine, and operate the machine according to the instructions.
- Do not use the machine in any way other than as described in this operation manual.

CONTENTS

General Safety Precautions	1
Special Instructions for Using the Mini Power Drive	3
Warranty	3
Names of Parts, Specifications	4
 Operation Guide	
Getting Ready	5
Start Up	5
Threading	6
Removing the threading head	7
 Care and maintenance	
Troubleshooting	8
Requesting Repairs	9
Parts list	10

Definitions of **▲ WARNING** and **▲ CAUTION**

In this operation manual, warnings are divided into **▲ WARNING** and **▲ CAUTION**.

▲ WARNING : indicates actions which could possibly result in death or severe injury to the user if the machine is used incorrectly.

▲ CAUTION : indicates actions which could possibly result in injury to the user, or physical damage, if the machine is used incorrectly.

Even items described as **▲ CAUTION**, could have serious results under certain conditions.

Be sure to observe these warnings carefully as they greatly affect safety.

- If this operation manual is lost or damaged, promptly order a replacement from our agent or sales agent.
- Parts and specifications are subject to change without prior notice due to improvements in quality, performance or safety standards. In such cases, the contents, photographs, illustrations, etc. of this manual may be different to the product you have purchased.

General Safety Precautions



WARNING

- 1) **Ensure you use the correct voltage.**
Be sure to use the voltage indicated on the name plate of the main unit or in the operation manual.
If the voltage is different from the voltage indicated, overheating, smoke or fire may occur.
- 2) **Check the switch is OFF before inserting the plug into the power supply socket.**
If the plug is inserted into the power supply when the switch is ON, the machine may start operation abruptly and is liable to cause accidents. Be sure to check the switch is OFF.
- 3) **Be sure to avoid electric shock.**
Do not touch the plug with wet hands.
Do not use the machine in rain or in places where water can easily get into the machine.
Be sure to ground the machine to avoid electric shock.
- 4) **Take notice of conditions at the work site.**
Do not use the machine in rain, humid or damp places, or places where water can easily get into the machine.
Humidity will lower insulation of the motor and cause electric shock.
Do not use close to flammable fluids or gases, such as gasoline and thinner. Fire or explosion might occur.
- 5) **Use designated accessories and attachments.**
Do not use accessories and attachments other than those designated in the operation manual or our catalogs. Accidents or injuries might result.
- 6) **In the following cases, turn the main unit OFF and pull the plug out of the power supply socket.**
When the machine is not in use or parts are changed, repaired, cleaned or inspected.
When accessories are changed.
When hazards are expected (including electric power failure)
When the plug is inserted, the main unit may start operation unexpectedly, causing accidents.
- 7) **If any abnormality is noticed, stop operation immediately.**
When the machine does not operate smoothly, or abnormalities such as unusual odors, vibration or noise are detected, stop operating the machine immediately.
Check symptoms against the items in the section entitled, "Troubleshooting" at the end of this manual and observe the corresponding instructions. If the machine is used continuously, overheating, smoke or fire might occur, causing accidents or injury.
If overheating or smoke from the unit occurs, do not attempt an overhaul yourself but ask for an inspection and repair.
- 8) **Keep the work site clean.**
Ensure you keep the work table and the work site in good order, and well lit.
A cluttered site and work table are liable to cause accidents.
- 9) **Do not let unauthorized personnel near the machine.**
Do not let any people other than authorised personnel touch the main unit or the power cord, or operate the machine.
Do not let anyone other than authorised personnel enter the work site, especially children.
Injuries might occur.
- 10) **Do not operate the machine with undue force.**
Use the machine only for its designated purpose. To ensure safety and efficiency, operate within the capacity of the unit.
Excessive force may result not only in damage to the product but also in accidents.
- 11) **Wear appropriate clothing.**
Do not wear neck ties, clothes with open sleeves, loose clothing, accessories such as necklaces, etc., which could get caught in the rotating parts.
When working outdoors, it is recommended that you wear rubber gloves and shoes with stoppers. Slippery gloves and shoes are liable to cause injuries.
Cover long hair with caps or hair nets, to prevent them getting caught in rotating parts.
Wear safety caps, safety shoes, etc. according to the working environment.

General Safety Precautions



WARNING

- 12) Do not work in an unnatural posture.
Keep a firm footing and balance to avoid falling over and injuring yourself.
- 13) Remove tools such as wrenches.
Before turning the machine ON, check that tools used for inspection and adjustment have been removed.
If you use the machine when tools are left inside it, accidents and injuries may occur.
- 14) Operate the unit with great care.
Always work with great attention to handling the machine, working methods and surrounding conditions. Carelessness may result in accidents and injuries.
Do not operate the machine when concentration is lowered such as when tired, after drinking alcohol, when sick, affected by medicines, etc.
- 15) Do not handle the power cord carelessly.
Do not carry the machine by the cord, or pull the plug out of the socket with the cord.
Do not place the cord near heated objects, fats & oils, cutters and objects with sharp edges.
Take care not to tread on the cord, pull the cord or apply unnecessary force resulting in damage to the cord.
Electric shock or short-circuit may occur, causing fire.
- 16) Perform careful maintenance daily.
When changing accessories and parts, follow the instruction manual.
Periodically inspect the power supply cord and plug. If damaged, ask your sales agent or our sales division for repairs.
If an extension cord is used, inspect the cord periodically and, if damaged, replace it.
If extension cords are used outdoors, use cords designed for outdoor use to prevent electric shock, short-circuit or fire.
Keep parts used for gripping dry and clean, and free of oil and grease. Slipping may cause injury.
- 17) Check for damaged parts.
Before using the machine, carefully check for damage to the protective cover and other parts, and check both normal operation and specified functions.
Check for any abnormalities such as in adjustment of movable parts, tightening, damage to parts, and all parts affecting operation.
Do not use machines if the stop and start switches do not work.
In replacing or repairing a broken protective cover and other parts, follow the operation manual.
If no instructions are specified in the operation manual, ask your sales agent or our sales division for repairs.
- 18) Store carefully when the machine is not in use.
Store in a dry place away from children and locked with a key.
- 19) For overhaul and repair of the machine, ask an appointed REX agent.
Our products comply with corresponding safety standards. Do not remodel.
Be sure to ask your sales agent or our sales division for any repairs.
If repairs are carried out by unskilled or unqualified personnel, the performance of the unit will be adversely affected and may result in accident or injury.
- 20) Do not use the machine for anything other than its intended purpose.
Doing so may result in accident, injury or damage to the machine.

Special Instructions for Using the Mini Power Drive

When using electrical tools, observe the following safety rules in order to reduce the risk of electric shock, injury and fire. Read and follow all of these instructions before using the threading machine.



WARNING

Take care when attaching the adapter.

Avoid hurting yourself when attaching or detaching the adapter.

Handle dies carefully.

The dies are sharp! Be careful when handling them and avoid cutting yourself.

Keep your machine clean.

For safe operation, keep the machine and threading heads free of swarf and the like. Keep the handles dry and free from oil and grease. Protect your machine against damage, and do not leave it in muddy or dusty places. At the end of the day, lock it up, together with its accessories, in a dry place and out of the reach of children.

Check the machine when idle.

Familiarize yourself with the machine's operation. Lubricate the machine before executing any threading operation.

Working with a generator.

When you use a generator, check that it has a minimum output power of 2.8 KW.

The use of attachments and accessories other than those indicated in this operation manual could result in personal injury.

Warranty

Warranty

REX is committed to the manufacture of high-quality machines and related accessories that have undergone rigorous testing from design to shipment. Thread cutting machines purchased from REX or its appointed agents are covered by a warranty for the lifetime of the machine that assumes its correct and responsible use. Within the terms of the warranty, REX's liability for repair or replacement is limited to defects that are proven to be the result of faulty materials or workmanship. The warranty does not apply to expendable parts or materials, such as dies, carbon brushes, etc., except where defects have occurred during the manufacturing process. Also excluded from the warranty are all defects caused by normal wear and tear, incorrect use, failure to comply with the operating instructions in this manual, operating the machine with excessive load, using inappropriate materials for which the machines were not designed, and any other reason for which REX cannot be held responsible.

The warranty will be deemed null and void if the machine has been tampered with, or repairs have been attempted by a third party such as an agent that is not approved by REX. All repairs must be performed by a REX-appointed agent that has been authorized to perform such repairs.

Claims will only be accepted if the machine is returned to REX or its appointed agents in an assembled state without prior repairs having been performed. All charges incurred in forwarding and returning the machine will be the responsibility of the user.

The warranty applies only to the original purchaser, who must provide proof of purchase by submission of the original invoice or sales slip.

Name of Parts, Specifications

■ Name of parts

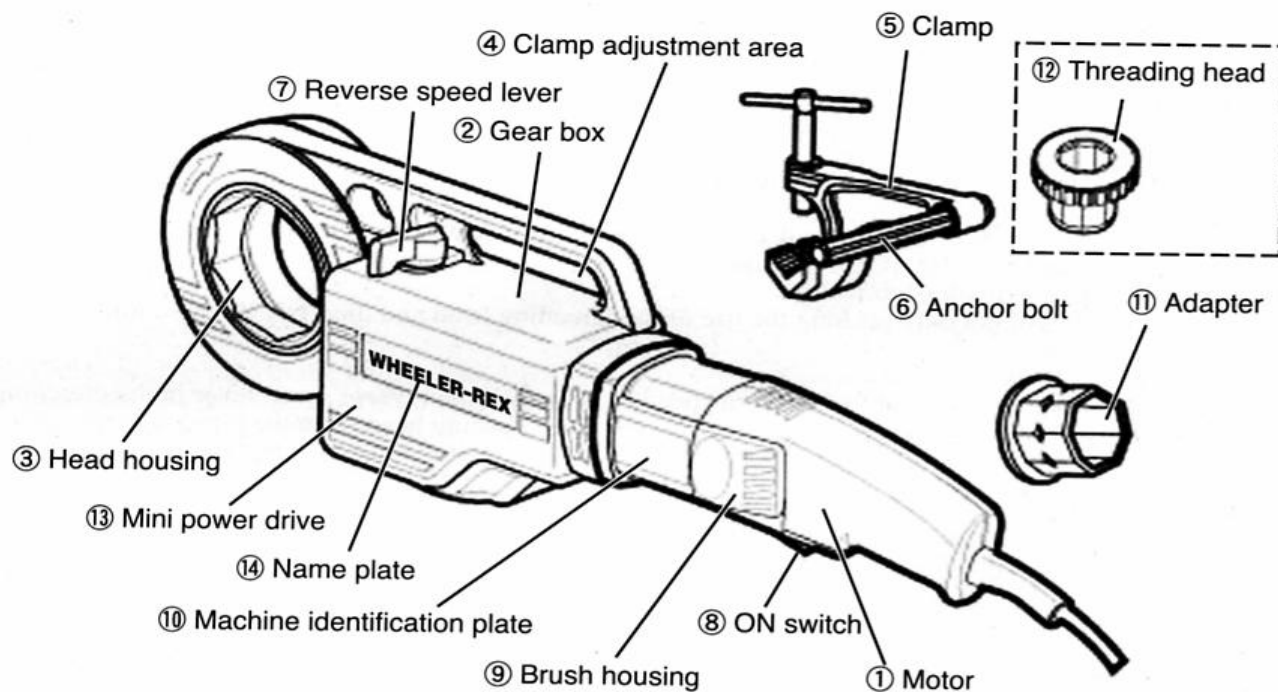

Fig.1

■ Specifications

Type	Mini Power Drive
Threading Capacity	1/8" - 2"
Type of Thread	NPT, NPSM, BSPT
Threading Speed	25 to 15 rpm
Fast Reverse Speed	58 rpm
Electric Current	120V 60 Hz (230V 50/60Hz)
Power Consumption	900W (1010W)
Switch	On/Off Dead Man (non locking)
Machine Weight	14.35 lbs (6.5kg)
Machine Dimensions	22.8" x 3.7" x 5.5" (580 x 95 x 140mm)
Clamp Weight	6lbs (2.7kg)
Gross Weight (full set)	35.3 lbs (16kg)
Carrying Case Dimensions	25.2" x 10/4" x 4/5" (640 x 263 x 114mm)
Lw	100dBA
Lp	87dBA
Vibration Level	<2.5 m/s

Operation Guide

Getting Ready

1. Do not thread pipes without using the safety clamp.
The clamp should be used even when threading the smallest sizes.
2. Check that the clamp is mounted correctly.
If the pipe is not fastened correctly, the machine will rotate on the threading head, with the consequent risk of injury to the operator. The anchor bolt is stored separately in the carrying case and should be screwed into the hole in the clamp. Then lock the anchor bolt with the accessory nut.
3. Check the ON switch
Check that the ON switch is automatically released when you let go of it.
4. Using extension cables
Check that the cable is both as thick and as short as possible. The extension cable should be more than 15 A, and not longer than 100 ft. (30 meters).
5. Ensure sufficient, continuous lubrication
Good lubrication will not only prolong the life of the threading head and dies, but will also improve the quality of the thread.
6. Always thread at working speed
Right threads should be made at the working speed indicated on the reverse speed lever in the direction of the arrow. High speed is only to be used to unscrew the threading head from the pipe.
For left threads, insert the threading head from the opposite side of the machine and maintain rotation in the work direction.
7. Do not change speeds while threading
Once threading is completed, stop the machine and change gears to initiate the reverse movement and to free the pipe.

Start Up

1. Before carrying out any operations with the machine, first read *General Safety Precautions* and *Getting Ready* above.
2. Fasten the clamp ⑤ securely and check that the anchor bolt ⑥ is parallel to the pipe to be threaded. Decide on the most appropriate distance between the clamp ⑤ and the mini power drive (see A in Fig. 5), so as to make the proper thread length, then clamp the pipe.
3. Select a suitable threading head ⑫ and attach the adapter ⑪.
Insert the threading head securely into the adapter, making sure you align the groove in the threading head ratchet with the stopper pin on the inside of the adapter. (Fig. 3)

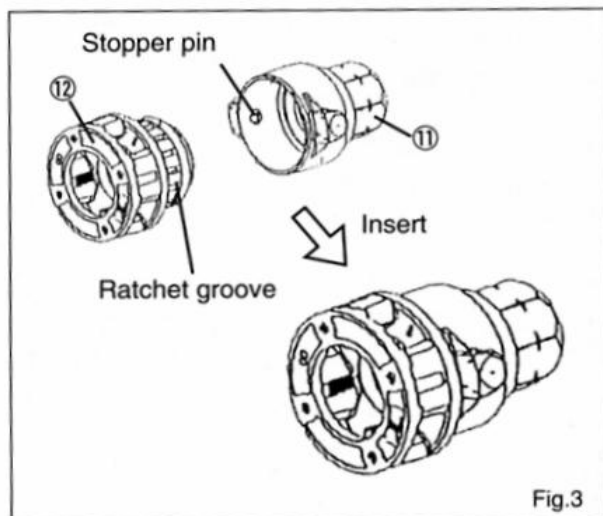
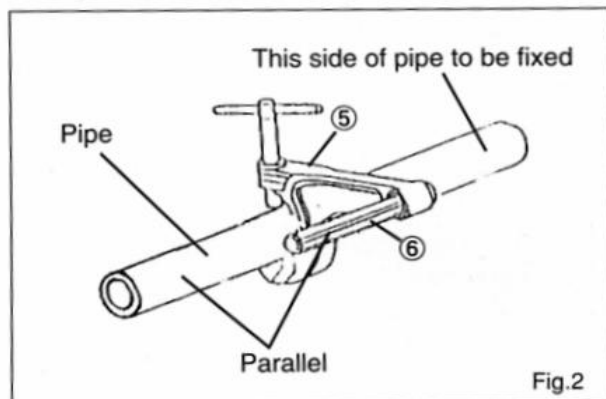

Operation Guide

4. With the threading head mounted, attach the adapter to the octagonal coupling on the mini power drive ⑬. When threading a pipe the adapter should be mounted from the front of the mini power drive, i.e. the side with the machine identification plate and the name plate. (Fig. 4) In the case of left threads, mount from the opposite side.

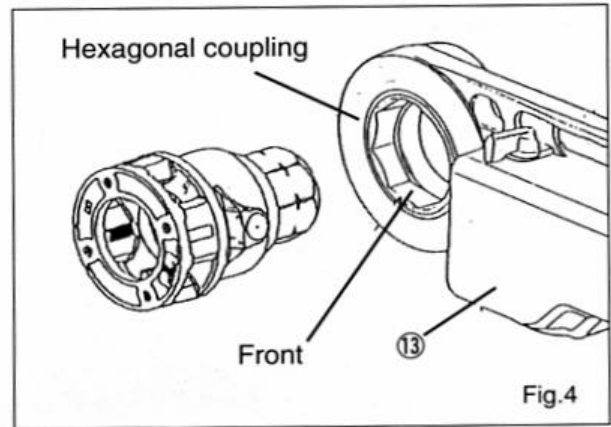

5. Next, insert a pipe in the mini power drive, making sure that the drive is properly secured by the anchor bolt on the clamp in the clamp adjustment area. (Fig. 5)
6. Check the reverse gear lever is in the correct position (arrow shows working position). Press the ON switch with your right hand and the machine will start rotating immediately. Start threading while pressing the threading head towards the pipe. Be careful not to injure your hands in the process.

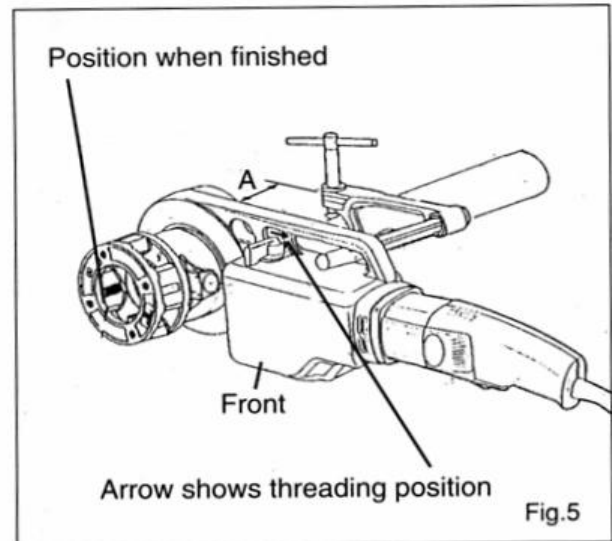

Threading

1. When making threads, keep the threading head well lubricated with Wheeler-REX or REX threading oil. (Fig. 6)

Warning: Use high speed (reverse) only when removing the threading head. Never use reverse to make threads.

2. Once the end of the pipe reaches the finished position (see Fig. 5), stop the motor. Change the position of the reverse gear lever and start the motor again. The threading head will be freed from the pipe.

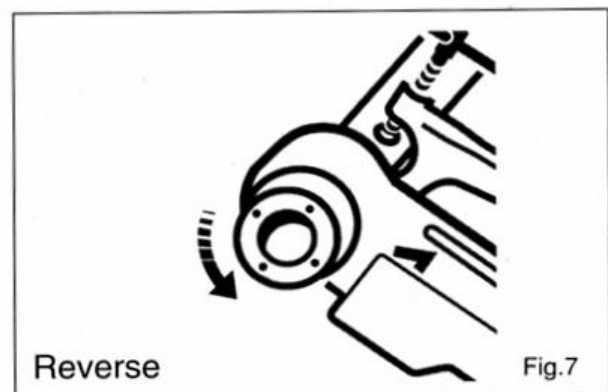

Operation Guide

Removing the threading head

1. When removing the threading head, first remove the adapter ⑪ from the mini power drive ⑬ and then remove the threading head ⑫ and adapter in the following order:

1-1. Holding the adapter ⑪ in your left hand and the threading head ⑫ in your right, pull them apart fairly vigorously. (Fig. 8)

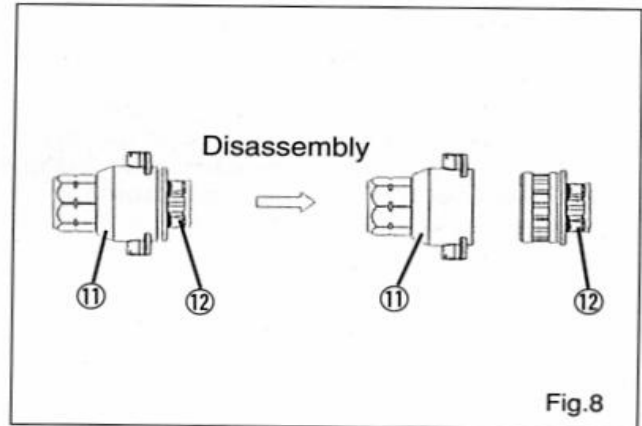

1-2 If the adapter ⑪ and threading head ⑫ are too tight to pull apart in the manner described in 5-1 above, try the following method:

For 1/8" ~ 1 1/2" threading heads:

Tap the end of the threading head ⑫ lightly with a rod that is a little larger than the inside diameter of the threading head itself. (Fig. 9)

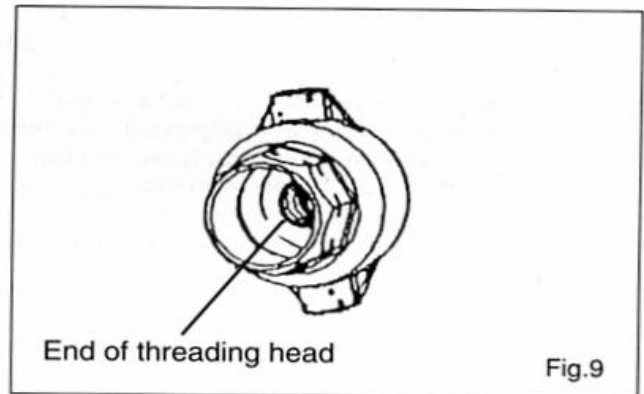

For 2" threading heads:

Insert a screwdriver, or similar narrow object, through the openings in the circumference of the threading head, as shown in the diagram opposite. Next, with a separate, thicker rod, gently tap the screwdriver away from the adapter. Avoid hitting the dies in the process. (Fig. 10)

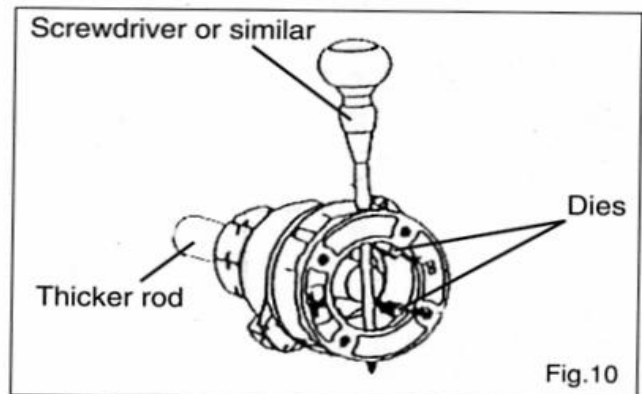

Care and Maintenance

▲ WARNING

Before carrying out any maintenance work, disconnect the plug from the power socket.

1. **Cable and plug**
Both the cable and plug should be in optimum condition. Check them at regular intervals.
2. **ON Switch**
Check that the machine automatically cuts off when you release your hand from the ON switch. In case of any abnormality, replace immediately with a new switch.
3. **Brushes**
Check frequently for brush wear and perfect contact with the rotor. Change brushes when they are reduced to 1/3 of their original length. Use only Wheeler-REX or REX brushes.
4. **Motor and rotor**
The carbon dust accumulated in the motor and brush housing should be removed every 100 hours. The motor's rotor should always be kept clean and have a uniform surface (light bronze color).
5. **Threading heads**
Check that there are no damaged teeth on the head to be used, as thread quality could deteriorate significantly. Keep clean of swarf to achieve top quality threading and longer life.
6. **Gear Box**
To increase the working life of the gears, change grease every 500 operating hours. After dismantling the machine, oil all mechanisms to eliminate old grease. Remove parts with dry compressed air and apply new grease with clean hands. Do not use solvents. Approximately 10oz (300 g) of grease is needed for correct lubrication. An excessive amount of grease is not recommended as it can increase the temperature of the machine. We recommend that this operation be carried out by authorized service and maintenance personnel.
7. **Dismounting the gear box**
Before removing the cover of the gear box, never insert pointed objects such as screwdrivers, etc. between the connecting faces of the body and cover. The correct procedure is to tap the front of the octagon gently with a plastic hammer.
8. **Clamp**
Check that the clamp is in good condition. Replace when pipe displacement occurs.
9. **Repair and maintenance should be done by a specialist**
All repairs should be carried out by a specialist and only original Wheeler-REX or REX parts should be used.

Troubleshooting

⚠ WARNING

Before carrying out any maintenance or repair on the machine, disconnect the plug from the power supply. If any servicing is required other than that indicated below, please contact your nearest Wheeler-REX or REX distributor or agent.

A. Insufficient power

- Make sure that the extension cable is not too long and that it is not damaged.
- Make sure that the right working speed is being used.
- Make sure the clamp is well secured (bolt parallel to pipe).
- Check the threading head is functioning correctly.
- Apply lubrication liberally to the threading head.

B. Off-center threading

- Check the position of the clamp (bolt should be parallel to the pipe).
- Check the condition and quality of the pipe.

C. Insufficient thread length

- Check that the clamp is in the correct position.
- Make sure that there is no obstruction between the machine and the clamp.

D. Poor thread quality

- Check the condition of the teeth.
- Check that there is adequate and continuous lubrication while threading.
- Check the quality of pipe.
- Check the quality of threading oil (use Wheeler-Rex or REX oil).

E. Incorrect adjustment of threading head

- Use the adapter for appropriate sizes (up to 1 1/4").
- Check that the appropriate threading head is being used (Wheeler-REX Drop Head or REX Drop Head 12R) .

F. Locked reverse speed lever

- If the lever is locked, move the machine up and down a little.

Requesting repairs

This machine is the result of precision design and manufacture. If it should fail to operate properly, do not attempt to repair it yourself; contact your dealer.

In the event that you require replacement parts or have any questions about the operation and handling of this machine, please contact Wheeler REX or your local distributor.

Parts List

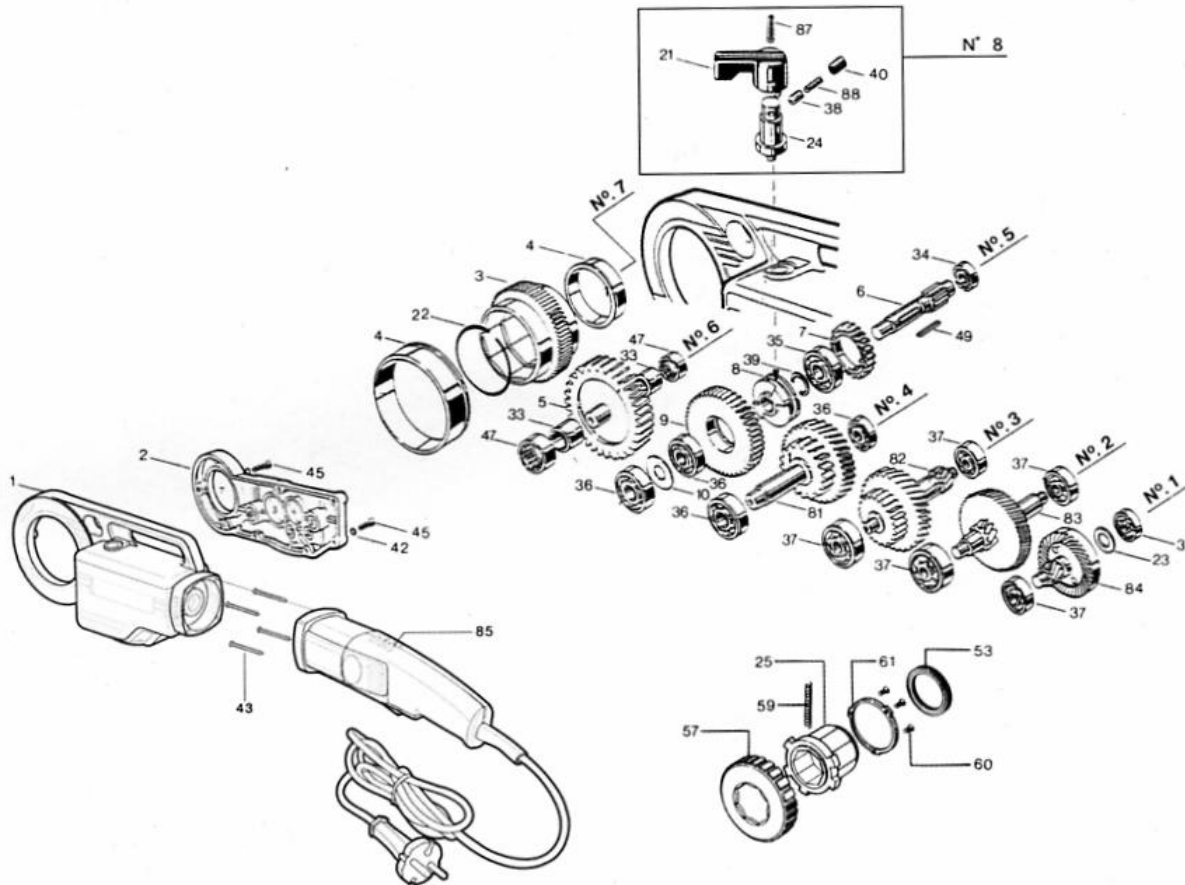

No.	Cod.
1	8640001
2	8640002
3	8620003 (2")
3	8610003 (1 1/4")
4	8620004
5	8620005
6	8620006
7	8620007
8	8620008
9	8620009
10	8620010
21	8620021
22	8620022 (2")
22	6000008 (1 1/4")
23	8620023
24	8620024
25	8620025
33	8620033

No.	Cod.
34	8620034
35	8620035
36	8620036
37	8620037
38	8620038
39	8620039
40	8620040
42	8620042
43	8640043
45	8620045
47	8620047
49	8620049
53	8620053
57	8620057
59	8620059
60	8620060
61	8620061
81	8620081

No.	Cod.
82	8620082
83	8620083
84	8620084
85	8640085 (230V)
85	8640088 (110V)
87	1021014
88	8620063
90	8620327
91	8620096

N° 1	8620064
N° 2	8620065
N° 3	8620066
N° 4	8620067
N° 5	8620075
N° 6	8620068
N° 7	8620069
N° 8	8620078

Parts List

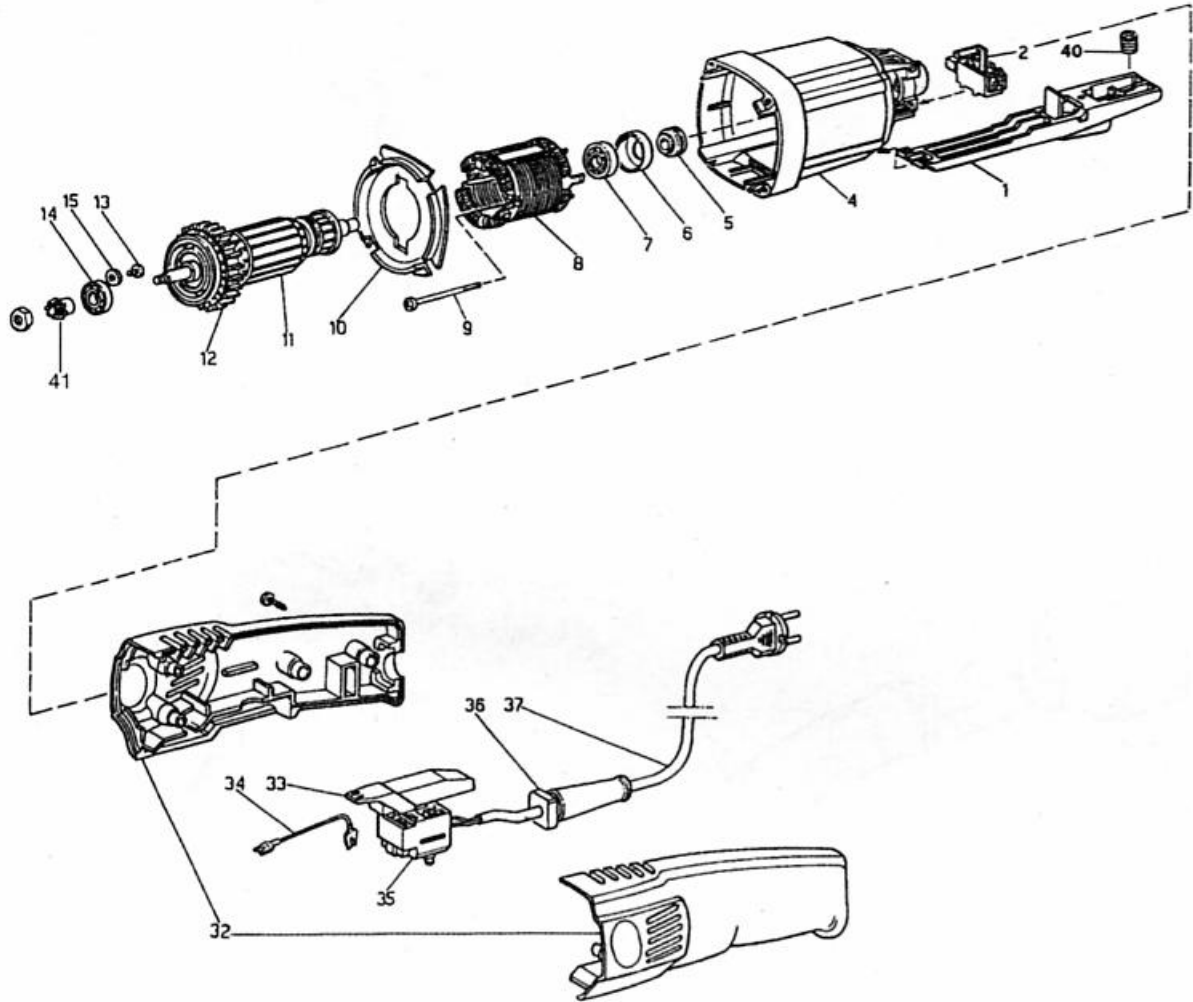

640 Parts List

Item No	Part Number	Description
1	6460	Switch Control
2	6410	Holder & Carbon Brush Set
4	6462	Motor Body
6	6463	Bearing Holder
7	6464	Bearing Holder
8	6465	Motor Body
9	6466	Spare Screw
10	6467	Deflector
11	6468	Armature
12	6469	Ventilator
13	6470	Screw
14	6471	Bearing Holder
15	6472	Washer
32	6473	Body Only
34	6474	Rod Connecting Stator
35	6475	Switch Control
36	6476	Cable Protector
37	6477	Cable
40	6478	Spring
41	6479	Pinion
	6480	Main Body Assembly w/gears
	6481	Handle Assembly w/cord